

# Laboratory Exercise 1

## Switches, Lights, and Multiplexers

The purpose of this exercise is to learn how to connect simple input and output devices to an FPGA chip and implement a circuit that uses these devices. We will use the switches  $SW_{9-0}$  on the DE1 board as inputs to the circuit. We will use light emitting diodes (LEDs) and 7-segment displays as output devices.

### Part I

The DE1 board provides 10 toggle switches, called  $SW_{9-0}$ , that can be used as inputs to a circuit, and 10 red lights, called  $LEDR_{9-0}$ , that can be used to display output values. Figure 1 shows a simple Verilog module that uses these switches and shows their states on the LEDs. Since there are 10 switches and lights it is convenient to represent them as vectors in the Verilog code, as shown. We have used a single assignment statement for all 10  $LEDR$  outputs, which is equivalent to the individual assignments

```
assign LEDR[9] = SW[9];
assign LEDR[8] = SW[8];
...
assign LEDR[0] = SW[0];
```

The DE1 board has hardwired connections between its FPGA chip and the switches and lights. To use  $SW_{9-0}$  and  $LEDR_{9-0}$  it is necessary to include in your Quartus II project the correct pin assignments, which are given in the *DE1 User Manual*. For example, the manual specifies that  $SW_0$  is connected to the FPGA pin *L22* and  $LEDR_0$  is connected to pin *R20*. A good way to make the required pin assignments is to import into the Quartus II software the file called *DE1\_pin\_assignments.csv*, which is provided on the *DE1 System CD* and in the University Program section of Altera's web site. The procedure for making pin assignments is described in the tutorial *Quartus II Introduction using Verilog Design*, which is also available from Altera.

It is important to realize that the pin assignments in the *DE1\_pin\_assignments.csv* file are useful only if the pin names given in the file are exactly the same as the port names used in your Verilog module. The file uses the names  $SW[0] \dots SW[9]$  and  $LEDR[0] \dots LEDR[9]$  for the switches and lights, which is the reason we used these names in Figure 1.

```
// Simple module that connects the SW switches to the LEDR lights
module part1 (SW, LEDR);
    input [9:0] SW;      // toggle switches
    output [9:0] LEDR;  // red LEDs

    assign LEDR = SW;
endmodule
```

Figure 1. Verilog code that uses the DE1 board switches and lights.

Perform the following steps to implement a circuit corresponding to the code in Figure 1 on the DE1 board.

1. Create a new Quartus II project for your circuit. Select Cyclone II EP2C20F484C7 as the target chip, which is the FPGA chip on the Altera DE1 board.
2. Create a Verilog module for the code in Figure 1 and include it in your project.

3. Include in your project the required pin assignments for the DE1 board, as discussed above. Compile the project.
4. Download the compiled circuit into the FPGA chip. Test the functionality of the circuit by toggling the switches and observing the LEDs.

## Part II

Figure 2a shows a sum-of-products circuit that implements a 2-to-1 *multiplexer* with a select input  $s$ . If  $s = 0$  the multiplexer's output  $m$  is equal to the input  $x$ , and if  $s = 1$  the output is equal to  $y$ . Part b of the figure gives a truth table for this multiplexer, and part c shows its circuit symbol.

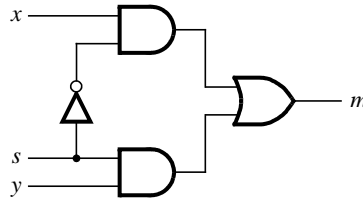

a) Circuit

$s$	$m$
0	$x$
1	$y$

b) Truth table

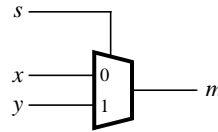

c) Symbol

Figure 2. A 2-to-1 multiplexer.

The multiplexer can be described by the following Verilog statement:

```
assign m = (~s & x) | (s & y);
```

You are to write a Verilog module that includes four assignment statements like the one shown above to describe the circuit given in Figure 3a. This circuit has two four-bit inputs,  $X$  and  $Y$ , and produces the four-bit output  $M$ . If  $s = 0$  then  $M = X$ , while if  $s = 1$  then  $M = Y$ . We refer to this circuit as an four-bit wide 2-to-1 multiplexer. It has the circuit symbol shown in Figure 3b, in which  $X$ ,  $Y$ , and  $M$  are depicted as four-bit wires. Perform the steps shown below.

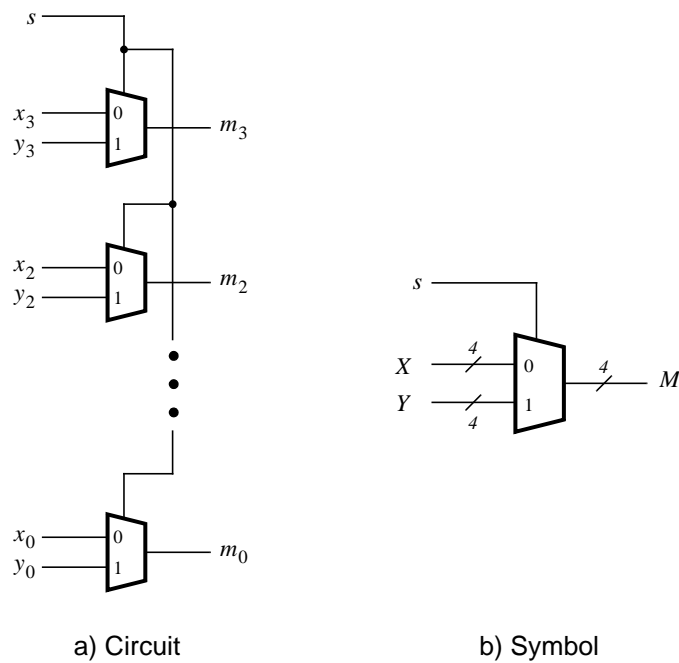

Figure 3. A four-bit wide 2-to-1 multiplexer.

1. Create a new Quartus II project for your circuit.
2. Include your Verilog file for the four-bit wide 2-to-1 multiplexer in your project. Use switch  $SW_9$  on the DE1 board as the  $s$  input, switches  $SW_{3-0}$  as the  $X$  input and  $SW_{7-4}$  as the  $Y$  input. Connect the  $SW$  switches to the red lights  $LEDR$  and connect the output  $M$  to the green lights  $LEDG_{3-0}$ .
3. Include in your project the required pin assignments for the DE1 board. As discussed in Part I, these assignments ensure that the input ports of your Verilog code will use the pins on the Cyclone II FPGA that are connected to the  $SW$  switches, and the output ports of your Verilog code will use the FPGA pins connected to the  $LEDR$  and  $LEDG$  lights.
4. Compile the project.
5. Download the compiled circuit into the FPGA chip. Test the functionality of the four-bit wide 2-to-1 multiplexer by toggling the switches and observing the LEDs.

### Part III

In Figure 2 we showed a 2-to-1 multiplexer that selects between the two inputs  $x$  and  $y$ . For this part consider a circuit in which the output  $m$  has to be selected from three inputs  $u$ ,  $v$ , and  $w$ . Part *a* of Figure 4 shows how we can build the required 3-to-1 multiplexer by using two 2-to-1 multiplexers. The circuit uses a 2-bit select input  $s_1s_0$  and implements the truth table shown in Figure 4*b*. A circuit symbol for this multiplexer is given in part *c* of the figure.

Recall from Figure 3 that an four-bit wide 2-to-1 multiplexer can be built by using four instances of a 2-to-1 multiplexer. Figure 5 applies this concept to define a two-bit wide 3-to-1 multiplexer. It contains two instances of the circuit in Figure 4*a*.

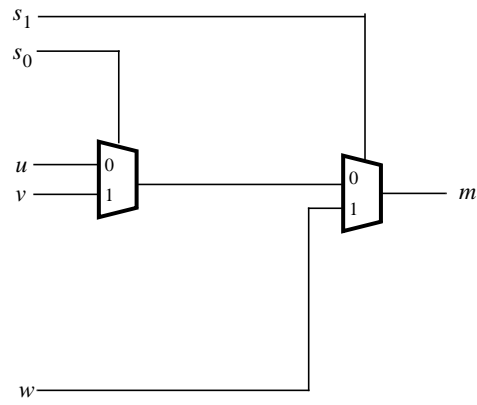

a) Circuit

$s_1$	$s_0$	$m$
0	0	$u$
0	1	$v$
1	0	$w$
1	1	$w$

b) Truth table

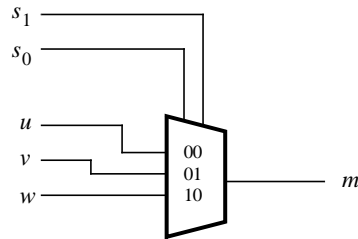

c) Symbol

Figure 4. A 3-to-1 multiplexer.

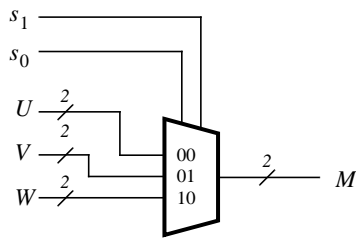

Figure 5. A two-bit wide 3-to-1 multiplexer.

Perform the following steps to implement the two-bit wide 3-to-1 multiplexer.

1. Create a new Quartus II project for your circuit.
2. Create a Verilog module for the two-bit wide 3-to-1 multiplexer. Connect its select inputs to switches  $SW_{9-8}$ , and use switches  $SW_{5-0}$  to provide the three 2-bit inputs  $U$  to  $W$ . Connect the  $SW$  switches to the red lights  $LEDR$  and connect the output  $M$  to the green lights  $LEDG_{1-0}$ .

3. Include in your project the required pin assignments for the DE1 board. Compile the project.
4. Download the compiled circuit into the FPGA chip. Test the functionality of the two-bit wide 3-to-1 multiplexer by toggling the switches and observing the LEDs. Ensure that each of the inputs  $U$  to  $W$  can be properly selected as the output  $M$ .

#### Part IV

Figure 6 shows a 7-segment decoder module that has the two-bit input  $c_1c_0$ . This decoder produces seven outputs that are used to display a character on a 7-segment display. Table 1 lists the characters that should be displayed for each valuation of  $c_1c_0$ . To keep the design simple, only three characters are included in the table (plus the 'blank' character, which is selected for codes 11).

The seven segments in the display are identified by the indices 0 to 6 shown in the figure. Each segment is illuminated by driving it to the logic value 0. You are to write a Verilog module that implements logic functions that represent circuits needed to activate each of the seven segments. Use only simple Verilog **assign** statements in your code to specify each logic function using a Boolean expression.

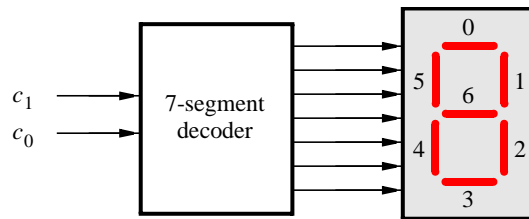

Figure 6. A 7-segment decoder.

$c_1c_0$	Character
00	d
01	E
10	1
11	

Table 1. Character codes.

Perform the following steps:

1. Create a new Quartus II project for your circuit.
2. Create a Verilog module for the 7-segment decoder. Connect the  $c_1c_0$  inputs to switches  $SW_{1-0}$ , and connect the outputs of the decoder to the  $HEX0$  display on the DE1 board. The segments in this display are called  $HEX0_0, HEX0_1, \dots, HEX0_6$ , corresponding to Figure 6. You should declare the 7-bit port

**output [0:6] HEX0;**

in your Verilog code so that the names of these outputs match the corresponding names in the *DE1 User Manual* and the *DE1\_pin\_assignments.csv* file.

3. After making the required DE1 board pin assignments, compile the project.
4. Download the compiled circuit into the FPGA chip. Test the functionality of the circuit by toggling the  $SW_{1-0}$  switches and observing the 7-segment display.

### Part V

Consider the circuit shown in Figure 7. It uses a two-bit wide 3-to-1 multiplexer to enable the selection of three characters that are displayed on a 7-segment display. Using the 7-segment decoder from Part IV this circuit can display any of the characters D, E, 1, and 'blank'. The character codes are set according to Table 1 by using the switches  $SW_{5-0}$ , and a specific character is selected for display by setting the switches  $SW_{9-8}$ .

An outline of the Verilog code that represents this circuit is provided in Figure 8. Note that we have used the circuits from Parts III and IV as subcircuits in this code. You are to extend the code in Figure 8 so that it uses three 7-segment displays rather than just one. You will need to use three instances of each of the subcircuits. The purpose of your circuit is to display any word on the four displays that is composed of the characters in Table 1, and be able to rotate this word in a circular fashion across the displays when the switches  $SW_{9-8}$  are toggled. As an example, if the displayed word is dE1, then your circuit should produce the output patterns illustrated in Table 2.

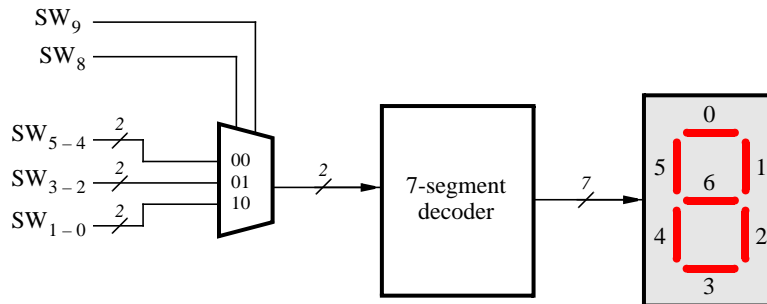

Figure 7. A circuit that can select and display one of three characters.

```

module part5 (SW, HEX0);
  input [9:0] SW;      // toggle switches
  output [0:6] HEX0;  // 7-seg displays

  wire [1:0] M;

  mux_2bit_3to1 M0 (SW[9:8], SW[5:4], SW[3:2], SW[1:0], M);
  char_7seg H0 (M, HEX0);
endmodule

// implements a 2-bit wide 3-to-1 multiplexer
module mux_2bit_3to1 (S, U, V, W, M);
  input [1:0] S, U, V, W;
  output [1:0] M;

  ... code not shown

endmodule

// implements a 7-segment decoder for d, E, 1 and 'blank'
module char_7seg (C, Display);
  input [1:0] C;      // input code
  output [0:6] Display; // output 7-seg code

  ... code not shown

endmodule

```

Figure 8. Verilog code for the circuit in Figure 7.

$SW_9 SW_8$	Character pattern
00	d E 1
01	E 1 d
10	1 d E

Table 2. Rotating the word dE1 on three displays.

Perform the following steps.

1. Create a new Quartus II project for your circuit.
2. Include your Verilog module in the Quartus II project. Connect the switches  $SW_{9-8}$  to the select inputs of each of the three instances of the three-bit wide 3-to-1 multiplexers. Also connect  $SW_{5-0}$  to each instance of the multiplexers as required to produce the patterns of characters shown in Table 2. Connect the outputs of the three multiplexers to the 7-segment displays  $HEX2$ ,  $HEX1$ , and  $HEX0$ .
3. Include the required pin assignments for the DE1 board for all switches, LEDs, and 7-segment displays. Compile the project.
4. Download the compiled circuit into the FPGA chip. Test the functionality of the circuit by setting the proper character codes on the switches  $SW_{5-0}$  and then toggling  $SW_{9-8}$  to observe the rotation of the characters.

## Part VI

Extend your design from Part V so that it uses all eight 7-segment displays on the DE1 board. Your circuit should be able to display words with three (or fewer) characters on the four displays, and rotate the displayed word when the switches  $SW_{9-8}$  are toggled. If the displayed word is dE1, then your circuit should produce the patterns shown in Table 3.

$SW_9$ $SW_8$	Character pattern
00	d E 1
01	d E 1
10	E 1 d
11	1 d E

Table 3. Rotating the word dE1 on eight displays.

Perform the following steps:

1. Create a new Quartus II project for your circuit and select as the target chip the Cyclone II EP2C20F484C7.
2. Include your Verilog module in the Quartus II project. Connect the switches  $SW_{9-8}$  to the select inputs of each instance of the multiplexers in your circuit. Also connect  $SW_{5-0}$  to each instance of the multiplexers as required to produce the patterns of characters shown in Table 3. (Hint: for some inputs of the multiplexers you will want to select the 'blank' character.) Connect the outputs of your multiplexers to the 7-segment displays  $HEX3, \dots, HEX0$ .
3. Include the required pin assignments for the DE1 board for all switches, LEDs, and 7-segment displays. Compile the project.
4. Download the compiled circuit into the FPGA chip. Test the functionality of the circuit by setting the proper character codes on the switches  $SW_{5-0}$  and then toggling  $SW_{9-8}$  to observe the rotation of the characters.